

The diamond and CBN wheels are for sharpening of tools for woodworking and plastic industries, automotive industry, jewelry, cutters sharpening, bearings grinding.

All grinding wheels can be adapted to different types of machines according to customer request.

Bore sizes of the grinding wheels can be adapted for each machine according to the customer request.

The bodies of the grinding wheels can be made of aluminum or steel.

It is possible to produce special designed grinding wheels for new projects and special grinding conditions.

## CONTENT

Shape of wheel	Page
1A1 (part I)	1
1A1 (part II)	2
14A1	2
12A2	3
12R4	3
12A2-45 <sup>0</sup>	4
6A2	5
9A3	5
1FF1	6
1EE1	6
14U1	6
14M1	7
1G1	7

# 1A1

Resin bond diamond and CBN grinding wheels

For carbide and HSS tools

For flute grinding, periphery grinding, relief grinding, radius shaping

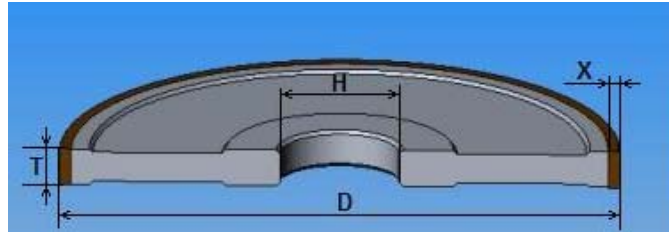

D, mm	T, mm	X, mm	H, mm	Body
16	8	2	6	Steel
20	10	2	6	Steel
25	10	3	6	Steel
32	10	3	10	Steel
40	10	3	16	Pressed
40	16	3	16	Pressed
50	10	3	16	Pressed
50	16	3	16	Pressed
63	10	3	20	Pressed
63	16	3	20	Pressed
80	4	3	20	Steel
80	6	3	20	Pressed
80	10	3	20	Pressed
80	20	3	20	Pressed
80	6	5	20	Pressed
80	10	5	20	Pressed
80	20	5	20	Pressed
100	6	3	20	Pressed
100	10	3	20	Pressed
100	20	3	20	Pressed
100	6	5	20	Pressed
100	8 (4+4)	5	32	Pressed
100	10	5	20	Pressed
100	20	5	20	Pressed
125	3	3	32	Steel
125	4	3	32	Steel
125	5	3	32	Steel
125	6	3	32	Pressed
125	10	3	32	Pressed
125	20	3	32	Pressed
125	6	5	32	Aluminum
150	6	3	32	Pressed
150	10	3	32	Pressed
150	20	3	32	Pressed
150	6	5	32	Pressed
150	6	5	120	Pressed
150	10	5	32	Pressed
150	20	5	32	Pressed

[Back to CONTENT](#)

## 1A1

Resin bond diamond and CBN grinding wheels

For carbide and HSS tools

For flute grinding, periphery grinding, relief grinding, radius shaping

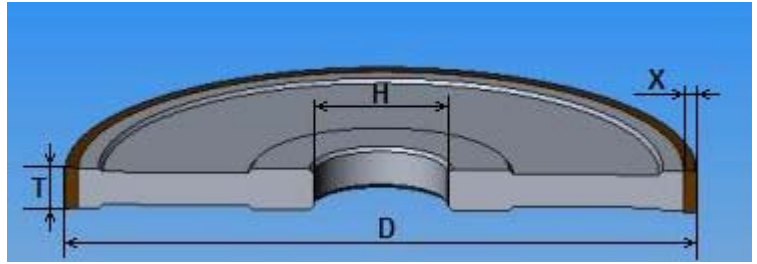

D, mm	T, mm	X, mm	H, mm	Body
200	6	3	76 (127)	Pressed
200	10	3	76 (127)	Pressed
200	10	5	76 (127)	Aluminum
200	20	5	76 (127)	Aluminum
250	10	5	76 (127)	Aluminum
250	15	5	76 (127)	Aluminum
250	20	5	76 (127)	Aluminum
250	40	5	76 (127)	Aluminum
300	15	5	76 (127)	Aluminum
300	20	5	76 (127)	Aluminum

[Back to CONTENT](#)

## 14A1

Resin bond diamond and CBN grinding wheels

For carbide and HSS tools

For flute grinding, periphery grinding, relief grinding, radius shaping

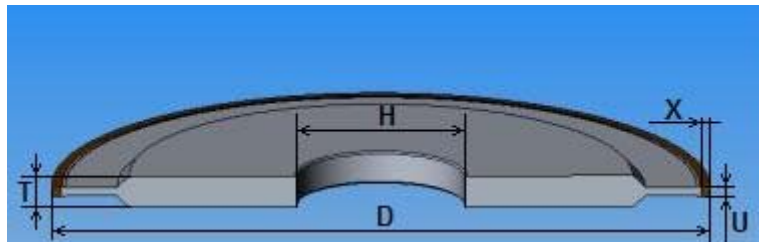

D, mm	T, mm	U, mm	X, mm	H, mm	Body
125	5	3	3	32	Steel
150	10	9	7	32	Aluminum
200	10	3	3	51	Steel
200	10	3	5	51	Steel
200	10	5	3	51	Steel
250	10	3	8	40	Steel
350	25	8	5	76(127)	Steel

[Back to CONTENT](#)

# 12A2

Resin bond diamond and CBN grinding wheels

For carbide and HSS tools

For grinding drills, cone envelop grinding, major cutting edge sharpening

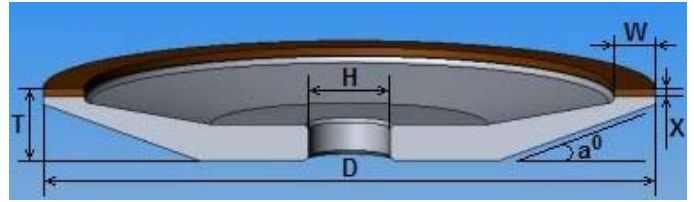

D, mm	a <sup>0</sup>	T, mm	W, mm	X, mm	H, mm	Body
50	20	10	3	3,2	16	Aluminum
75	20	10	3	2	16	Pressed
75	20	10	6	2	16	Pressed
100	20	12	3	2	20	Pressed
100	20	12	6	2	20	Pressed
100	15	12	6	2	20	Pressed
125	20	16	3	2	32	Pressed
125	20	16	6	2	32	Pressed
125	20	16	10	2	32	Pressed
125	20	18	6	4	32	Pressed
125	35	19	10	3,5	32	Pressed
125	20	19	8(4+4)	5	32	Pressed
125	20	13	6	1,7	20(32)	Aluplast
150	20	18	6	2	20(32)	Pressed
150	20	18	10	2	20(32)	Pressed
150	20	19	6	3	32	Pressed
150	20	19	10	3	32	Pressed
150	20	21	6	5	32	Pressed
150	20	21	10	5	32	Pressed
150	20	16	6	1,7	16(20;32)	Aluplast

[Back to CONTENT](#)

# 12R4

Resin bond diamond and CBN grinding wheels

For carbide and HSS tools

For grinding of front surfaces of saw blades

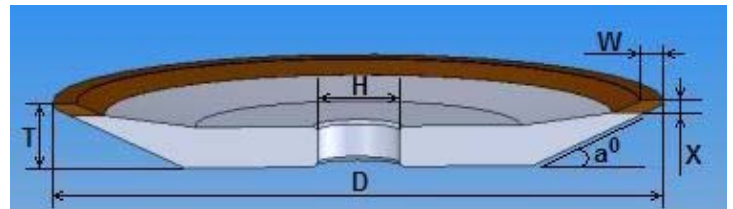

D, mm	a <sup>0</sup>	T, mm	W, mm	X, mm	H, mm
75	25	10	3	2	20
100	25	10	3	2	32
125	25	13	3	2	32
150	25	16	5	3	20(32)

[Back to CONTENT](#)

# 12A2-45

Resin bond diamond and CBN grinding wheels

For carbide and HSS tools

For grinding drills, cone envelop grinding, edge sharpening

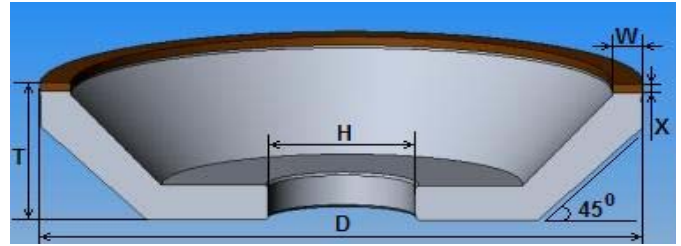

D, mm	T, mm	W, mm	X, mm	H, mm	Body
50	21	3	3	16	Pressed
75	21	3	3	16	Pressed
75	21	6	3	16	Pressed
75	26,5	3	3	20	Pressed
75	26,5	6	3	20	Pressed
100	32	3	3	20	Pressed
100	32	5	3	20	Pressed
100	32	10	3	20	Pressed
125	40	3	3	32	Pressed
125	40	5	3	32	Pressed
125	40	10	3	32	Pressed
125	42	5	5	32	Pressed
125	42	10	5	32	Pressed
150	26	10	3	32	Pressed
150	28	10	5	32	Pressed
150	40	5	3	32	Pressed
150	40	10	3	32	Pressed
150	40	20	3	32	Pressed
150	42	5	5	32	Pressed
150	42	10	5	32	Pressed
150	42	20	5	32	Pressed
200	50	10	3	51	Aluminum
200	52	10	5	51	Aluminum
200	50	20	3	51	Aluminum
200	52	20	5	51	Aluminum

# 6A2

Resin bond diamond and CBN grinding wheels

For carbide and HSS tools

For grinding of back surfaces of tooth of saw blades,

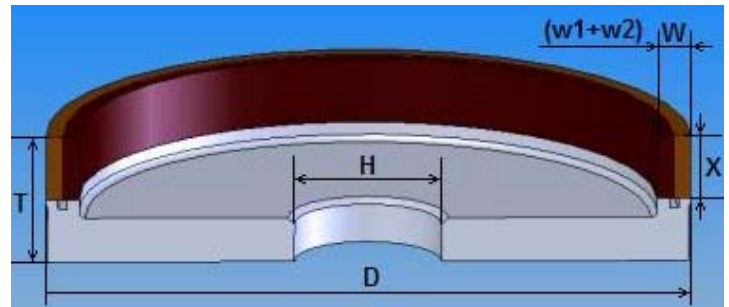

D, mm	T, mm	W, mm	X, mm	H, mm	Body
100	24	5(2,5+2,5)	6	25(32)	Aluminum
100	20	5(2,5+2,5)	10	25(32)	Aluminum
125	24	5(2,5+2,5)	6	25(32)	Aluminum
125	20	5(2,5+2,5)	10	25(32)	Aluminum
150	20	20	3	32	Aluminum
150	20	40	3	32	Aluminum
150	20	40	5	32	Aluminum
150	24	10	4	32	Pressed
150	24	20	4	32	Pressed

[Back to CONTENT](#)

# 9A3

Resin bond diamond and CBN grinding wheels

For carbide and HSS tools

For one pass through slots grinding

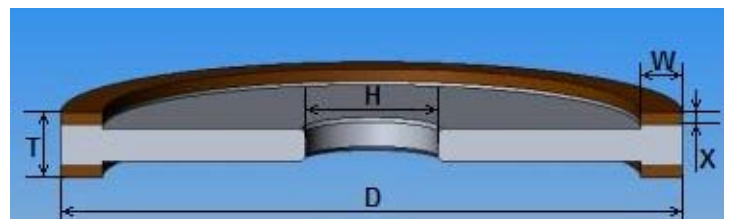

D, mm	T, mm	W, mm	X, mm	H, mm	Body
150	16	10	3	32	Aluminum
150	16	20	3	32	Aluminum
200	16	20	3	32	Aluminum
250	21	10	3	76	Aluminum
250	21	20	3	76	Aluminum

[Back to CONTENT](#)

## 1FF1

Resin bond diamond and CBN grinding wheels

For carbide and HSS tools

For point thinning of cutting edges, profile grinding of milling cutters,

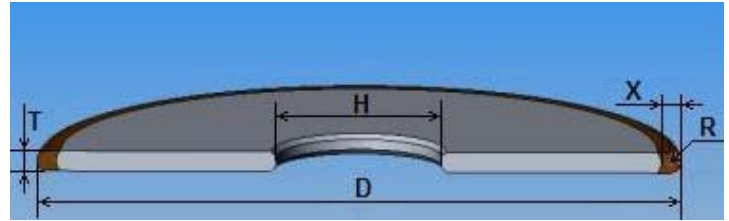

D, mm	T, mm	X, mm	R, mm	H, mm	Body
125	4	4	2	32	Steel
125	12	6	6	32	Aluminum
200	3	4	1,5	60	Steel
200	4	4	2	60	Steel

[Back to CONTENT](#)

## 1EE1

Resin bond diamond and CBN grinding wheels

For carbide and HSS tools

For threads polishing, profile grinding

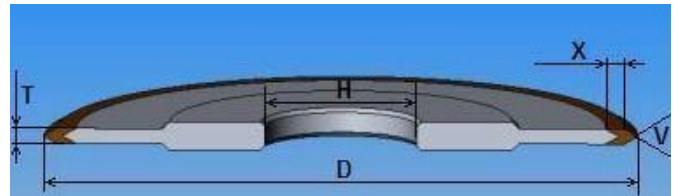

D, mm	a <sup>0</sup>	T, mm	X, mm	H, mm	Body
125	35 <sup>0</sup>	3	6	32	Steel
125	45 <sup>0</sup>	3	5	32	Steel
125	60 <sup>0</sup>	3	4	32	Steel
125	30 <sup>0</sup>	3	6	32	Steel
150	45 <sup>0</sup>	3	5	32	Steel
150	60 <sup>0</sup>	3	4	32	Steel

[Back to CONTENT](#)

## 14U1

Resin bond diamond and CBN grinding wheels

For carbide and HSS tools

For one pass through slots grinding, peripheral grinding

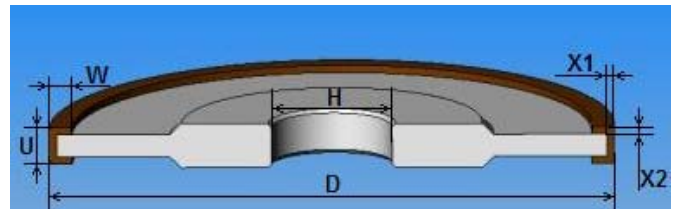

D, mm	U, mm	W, mm	X1, mm	X2, mm	H, mm	Body
150	10	6	2	2	32	Aluminum

[Back to CONTENT](#)

## 14M1

Resin bond diamond and CBN grinding wheels

For carbide and HSS tools

For tooth sharpening of mills, saw blades

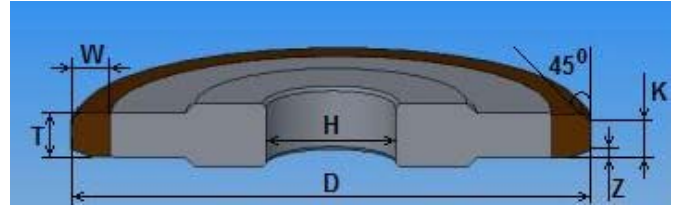

D, mm	T, mm	W, mm	Z, mm	K, mm	H, mm	Body
80	7	4,5	0,9	2,7	20	Aluminum
80	7	4,5	1,4	2,9	20	Aluminum
80	7	4,5	1,9	3,2	20	Aluminum
80	7	5	2,4	3,7	20	Aluminum
80	8	5	2,8	3,9	20	Aluminum
80	9	5,5	3,2	4,3	20	Aluminum
80	9	6	3,7	4,8	20	Aluminum
80	10	7	4,5	5,7	20	Aluminum

[Back to CONTENT](#)

## 1G1

Resin bond diamond and CBN grinding wheels

For carbide and HSS tools

For profile grinding. Often is used in pair side by side

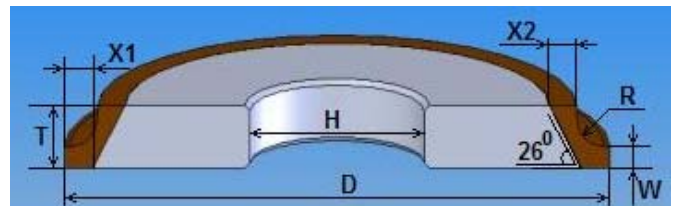

D, mm	T, mm	R, mm	W, mm	X1, mm	X2, mm	H, mm	Body
100	12	5	4	5	5	32	Aluminum

[Back to CONTENT](#)